

# LP Cooab Commercial experiences

Peter Thulin  
Marketing Director  
Purac Division

# Läckeby Water Group Key figures

- Annual sales: 70 million Euro
- Number of employees: 210
- Established 1935
- Presence in ten different countries
- KF Invest majority owner

# Purac provides

- Municipal wastewater treatment plants
- Municipal water works
- Proceswater treatment for industrial use  
Pulp & Paper, Food industry
- Industrial effluent treatment
- Biogasplants and biogasupgrading



# Svensk Biogas in, Linköping Sweden





Sobacken, Borås – Biogasanläggning till hushållsavfall och verksamhetsavfall



Borås Energi & Miljö AB

# 35 years experience of biogas and anaerobic procesec

- Digestion of sludge from municipal wastewater treatment
- Anamet proces for high concentrated industrial effluent
- High rate anaerobic technolgies for effluent from breweries, recycled papaer mills and similar
- Co digestion of solid organic waste
- In total more than 100 reference plants

# Experiences in Sweden

- Biogasupgrading started in mid 90's
- Different technologies - PSA, waterscrubbers, Seloxol and membranes
- Performance problems, design errors
- Reluctance to new technologies e.g. LP-Cooab

# Introduction of LP - Cooab

- A lot of problems with earlier introduced technologies – No more new problems
- Tenders, information, meetings...
- Borås made the first brave decision
- Göteborg Energi, Arendal The BIG breakthrough

# The COOAB process

- Low pressure reversible chemical absorption of CO<sub>2</sub>.
- COOAB is the trade name of a special amine composition.
- COOAB is the absorption liquid mixed with 50% water in a circulating sealed system.
- Widely used in the field of natural gas.

# Göteborg Energi –Arendal biogas Biogasupgrading – Biogasflow 1.600 Nm<sup>3</sup>/h.



# H<sub>2</sub>S-adsorption

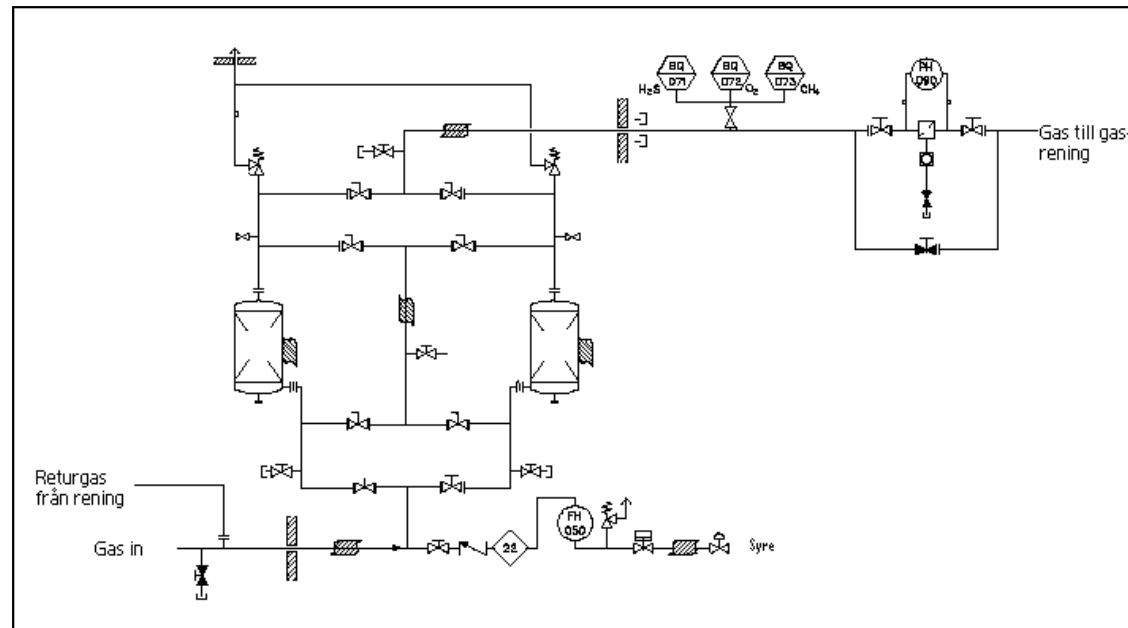

- Activated carbon filters where H<sub>2</sub>S is adsorbed
- Oxidation to elementary sulphur and water

# Gas upgrading

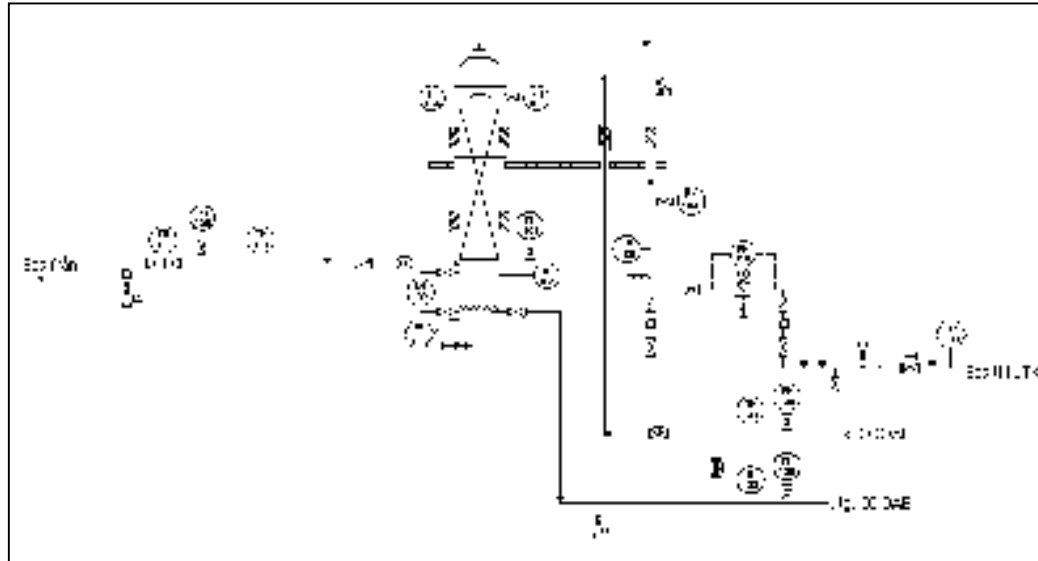

- Chemical absorption of  $\text{CO}_2$  in COOAB
- 12 m high tower with surface expanding elements

# First Lp Cooab plant in Borås 2003



# Regeneration of COOAB

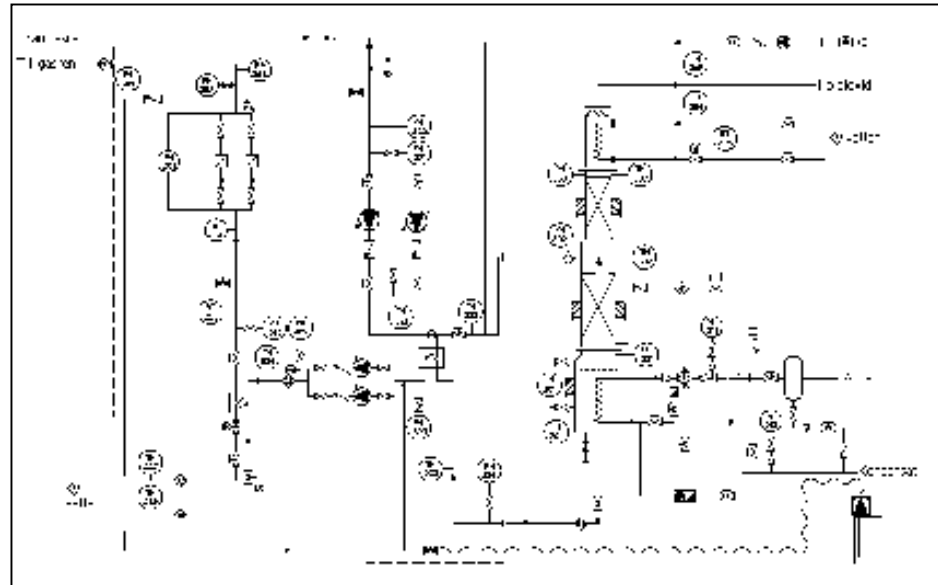

- Steam heated stripper tower
- Pure carbon dioxide can be collected
- The COOAB is cooled and used again for absorption

# Benefits of COOAB technology

- Upgrading at low pressure – approx. 4 bar.
- Reduced electrical energy consumption.
- Excess heat can be used for heating of e. g. digesters and buildings.
- CO<sub>2</sub> from the stripper is almost pure and can be used in greenhouses or be further upgraded to industrial or food grade quality.

# Benefits of COOAB technology

- > 99.9% methane recovery.
- No methane loss to the atmosphere.
- Reduced cost for propane addition to reach natural gas quality.
- CH<sub>4</sub> causes more than 20 times as high effect on global warming than CO<sub>2</sub>.

# E.ON Falkenberg biogas Pre-fab unit Capacity 800 Nm<sup>3</sup>/h



# IVAR, Stavanger, Capacity 500 Nm<sup>3</sup>/h Opening ceremony 2009



# LP COOAB Track record

- Borås plant no 1 – 2003, 450 Nm<sup>3</sup>/h
- Göteborg Energi, Arendal 2005, 1.600 Nm<sup>3</sup>/h
- E.ON, Falkenberg 800 Nm<sup>3</sup>/h, 2008/2009
- IVAR, Stavanger, 2009, 500 Nm<sup>3</sup>/h
- SYVAB, Stockholm, 2009 800 Nm<sup>3</sup>/h,
- Kalmar , 200 Nm<sup>3</sup>/h, 2009
- Bekkelaget, Oslo, 800 Nm<sup>3</sup>/h, fall 2009
- Weltech, Könnern, 3.4000 Nm<sup>3</sup>/h, fall 2009
- Karlstad, 500 Nm<sup>3</sup>/h, 2010

# Conclusions

- New technologies takes time to introduce
- If the technology is good it will be accepted
- A forerunner is of great help
- Grants or premiums for new technologies is an efficient catalyst
- Do a good homework before you start

An environmental group  
for sustainable growth

[www.purac.se](http://www.purac.se)