

„Overview on (biogas) upgrading technologies“



Dipl.-Ing. Michael Beil, Dipl.-Ing. Uwe Hoffstede, ISET, Division Bio-energy Systems Technology
“European Biomethane Fuel Conference”, Göteborg/Sweden, 2009-09-09

BIOGASMAX

Biogas as vehicle fuel – Market Expansion to 2020 Air Quality



The overall objective is the demonstration of the well to wheel path – biogas production, upgrading to biomethane, distribution and utilisation as vehicle fuel



[ISET]

Activities ISET:

- Monitoring and evaluation of biogas production plants
- Monitoring and evaluation of biogas upgrading plants
- Tests using new technologies for biogas pretreatment
- Knowledge transfer in the area of biogas production and upgrading to biomethane

BIOGASMAX

Biogas as vehicle fuel – Market Expansion to 2020 Air Quality



Workpackages

- | | |
|-----------------------------|--|
| 1 projekt management | 5 use in vehicles |
| 2 biogas production | 6 evaluation |
| 3 upgrading | 7 transferability studies |
| 4 distribution | 8 communication and dissemination |

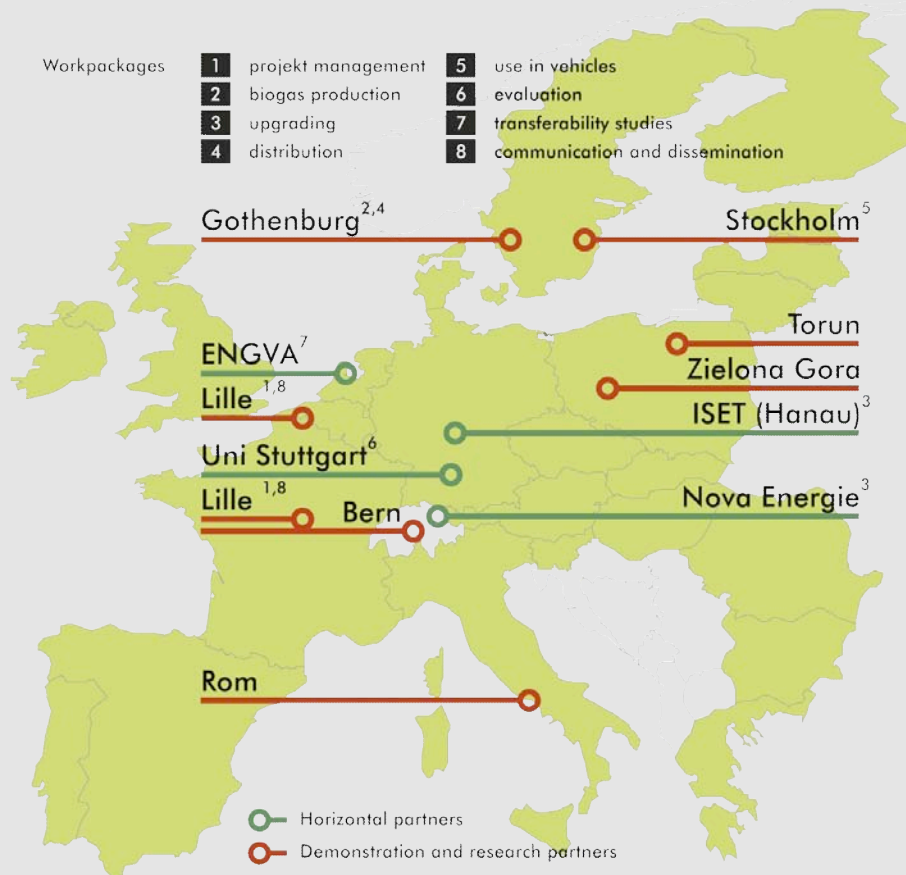

Biogasmax main partners in Europe

Monitoring programme and demonstration sites:

- Berne (CH)
- Lucerne (CH)
- 2xLille (F)
- Göteborg (S)
- Falköping (S)
- Västeras (S)
- Linköping (S)
- Stockholm (S)

What is Biogas?

What is biogas?

- ÿ **Gas mixture**
- ÿ **Produced in an anaerobic digestion process**
- ÿ **Possible feedstock material: All good degradable organic materials**
 - ÿ Digester sludge
 - ÿ Manure (liquid & solid)
 - ÿ Organic waste (Household waste, restaurant waste, food industry waste, etc.)
 - ÿ Energy crops (silage of maize, grass, corn, etc.)

Composition of biogas:

- **Methane CH₄** (50 – 75 %)
→ *Main component of natural gas*
- **Carbon dioxide CO₂** (25 – 45 %)
- **Water H₂O**
- **Nitrogen N₂**
- **Oxygen O₂**
- **Ammonia NH₃**
- **Hydrogen sulphide H₂S**
- **Other trace gases (e.g. hydrogen, siloxanes, etc.)**

Different kinds of biogas...

...corresponding to different kinds of feedstock:

- **Sewage gas / Sludge gas (wastewater treatment plants)**
- **Biogas from agricultural sources (manure, energy crops)**
- **Biogas from waste**
 - or mixtures of it (so called Co-digestion)
- **Landfill gas**

Different kinds of biogas in the project...



...corresponding to different kinds of feedstock:

- **Sewage gas / Sludge gas (wastewater treatment plants)**
- **Biogas from agricultural sources (manure, energy crops)**
- **Biogas from waste**
 - **or mixtures of it (so called Co-digestion)**
- **Landfill gas**

Primary production of biogas in Europe 2007

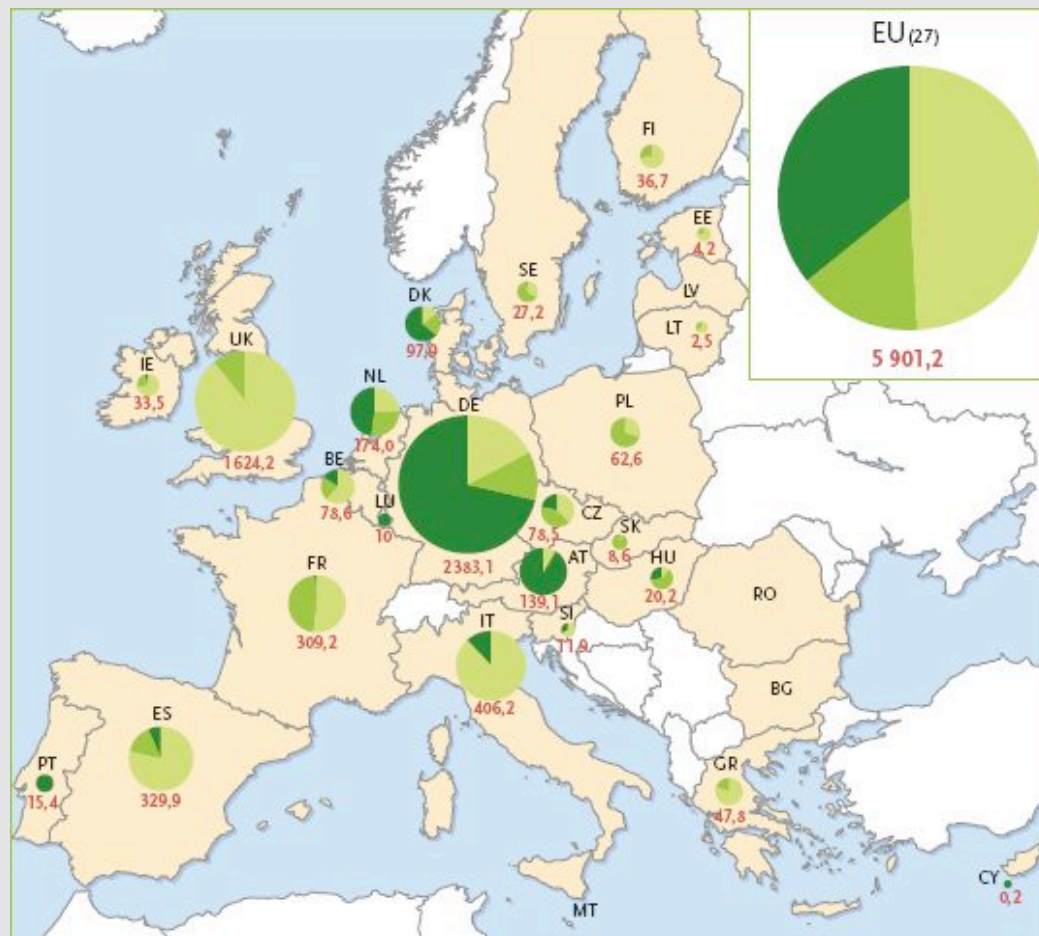

In ktOE

(1.000 tons oil equivalent):

EU: 5.901 ktOE = 69 TWh

- Biogaz de décharges/Landfill gas
- Biogaz de stations d'épuration/Sewage sludge gas
- Autres biogaz (déchets agricoles, etc.)/Other biogases (agricultural waste, etc.)

[EurObserv'ER, 2007]

How to produce biomethane?

Overview biogas upgrading technologies (for CO₂ - reduction)

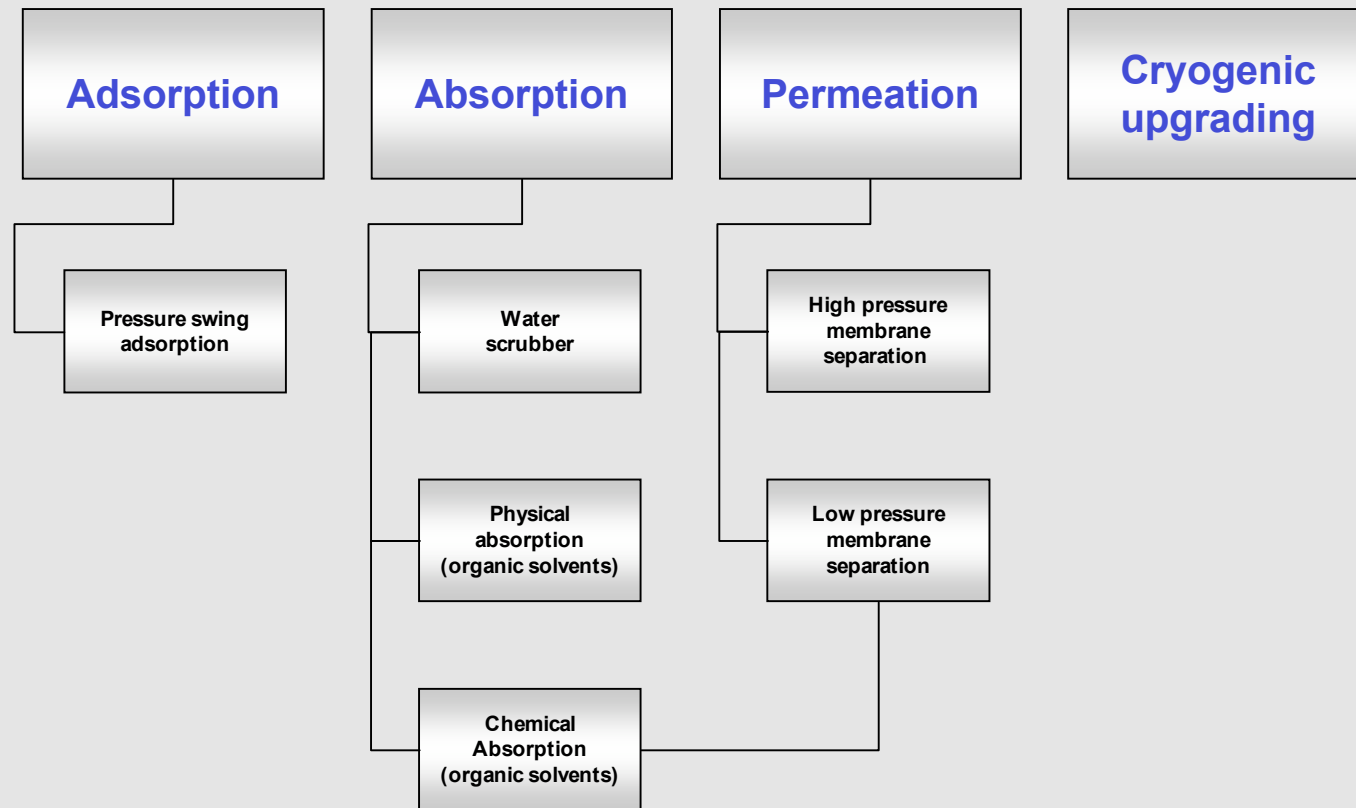

[ISET, 2008]

Pressure Swing Adsorption

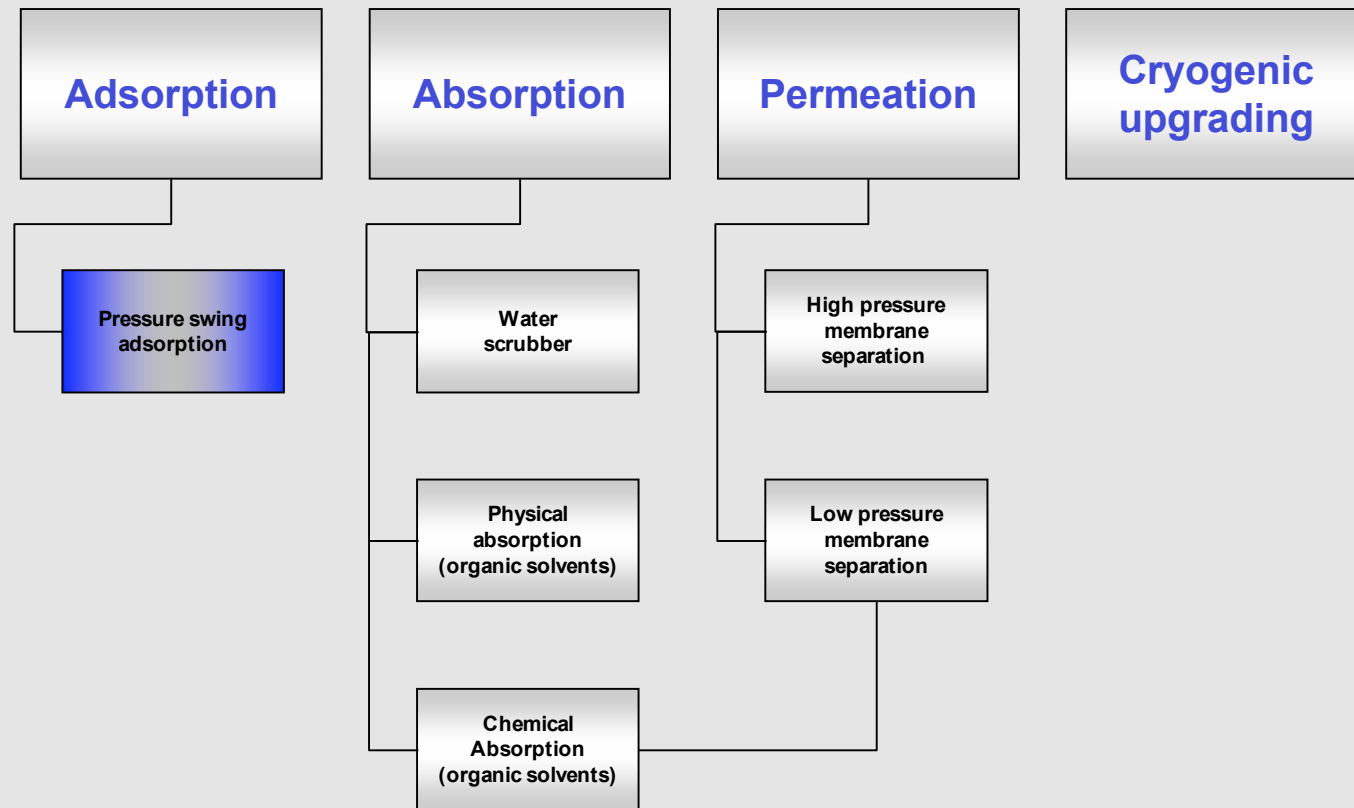

[ISET, 2008]

Pressure Swing Adsorption

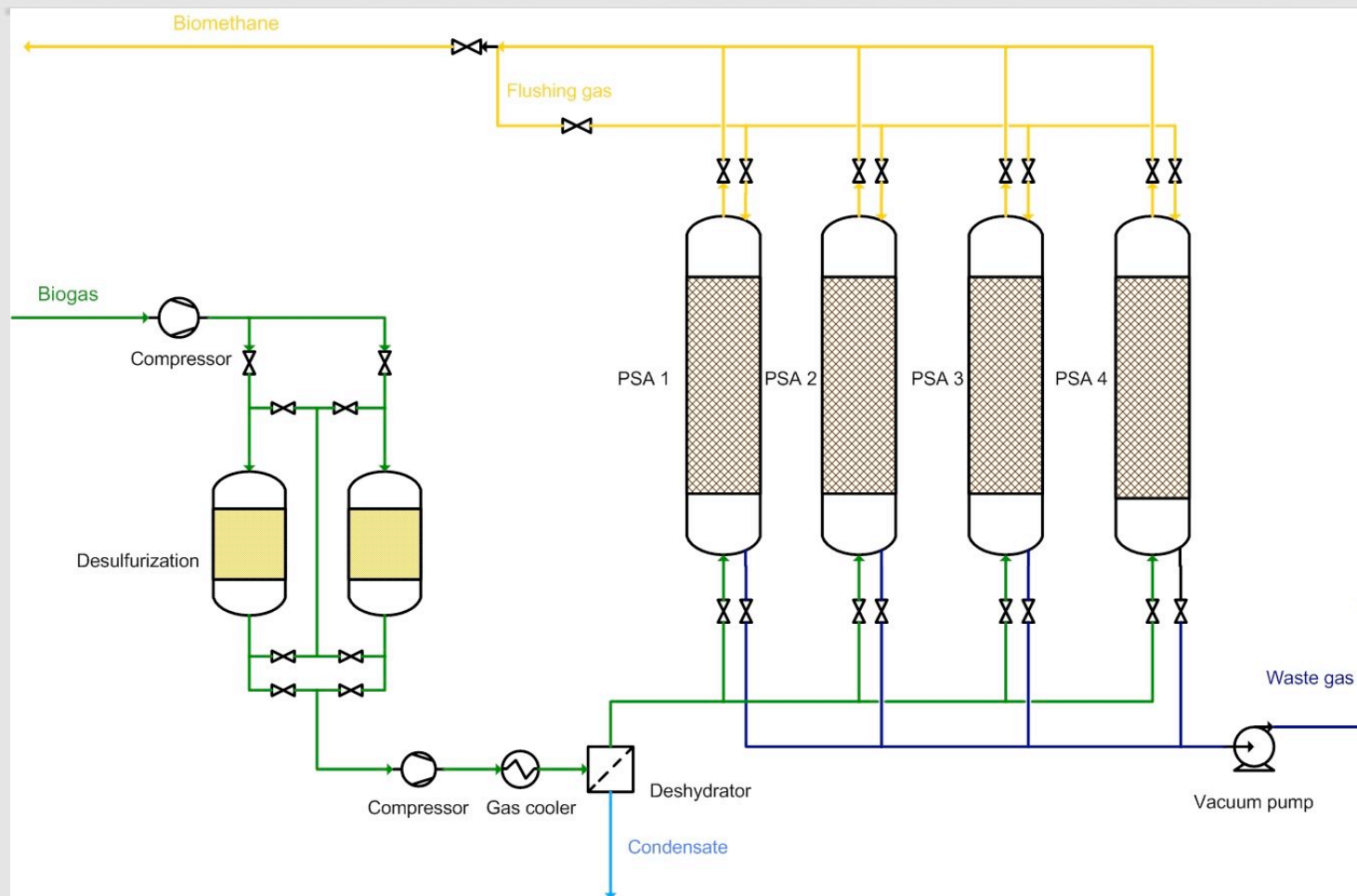

H₂S

H₂O

CO₂

[ISET, 2008]

Pressure Swing Adsorption

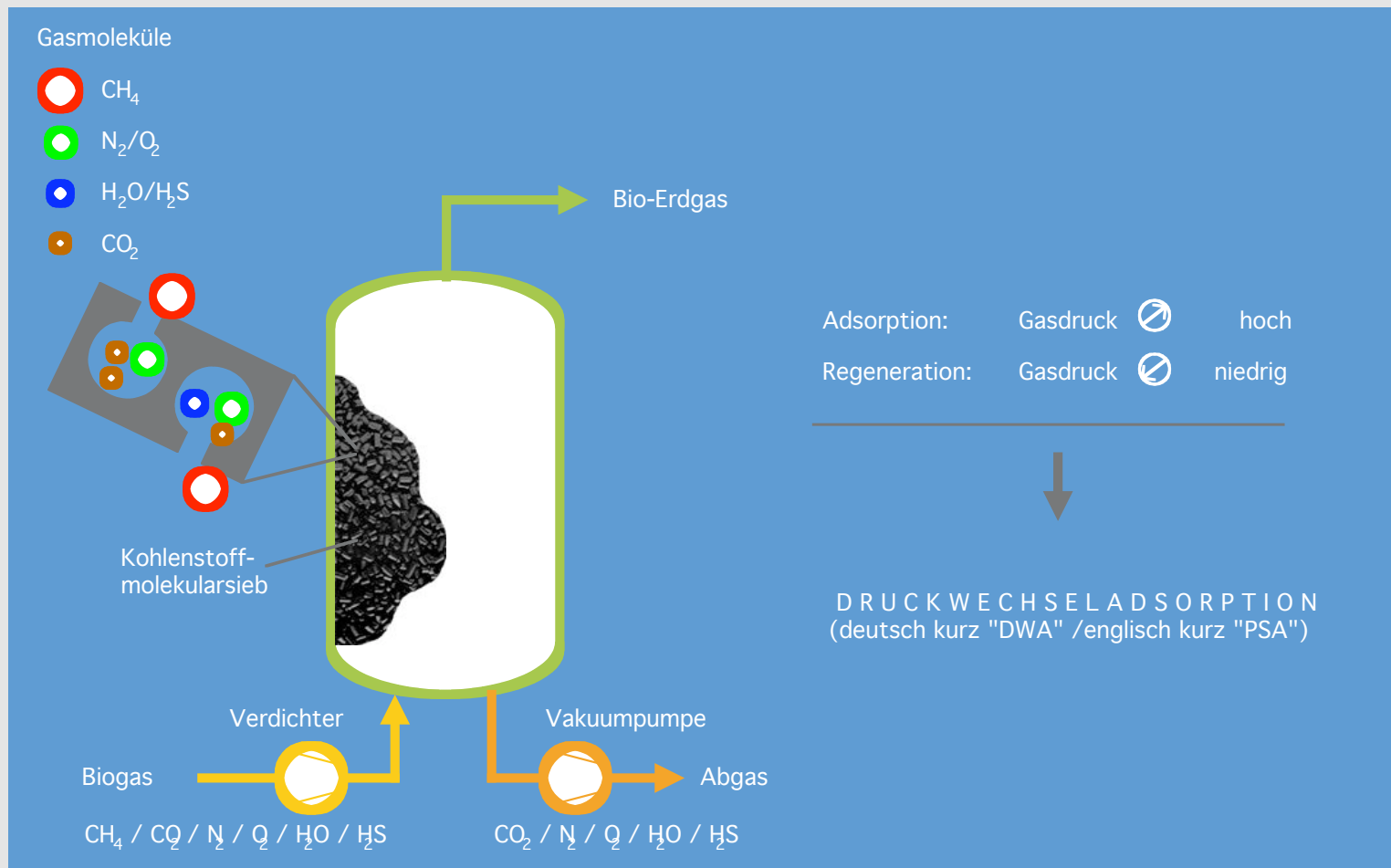

[CarboTech, 2008]

Pressure Swing Adsorption: 2000 Nm³/h

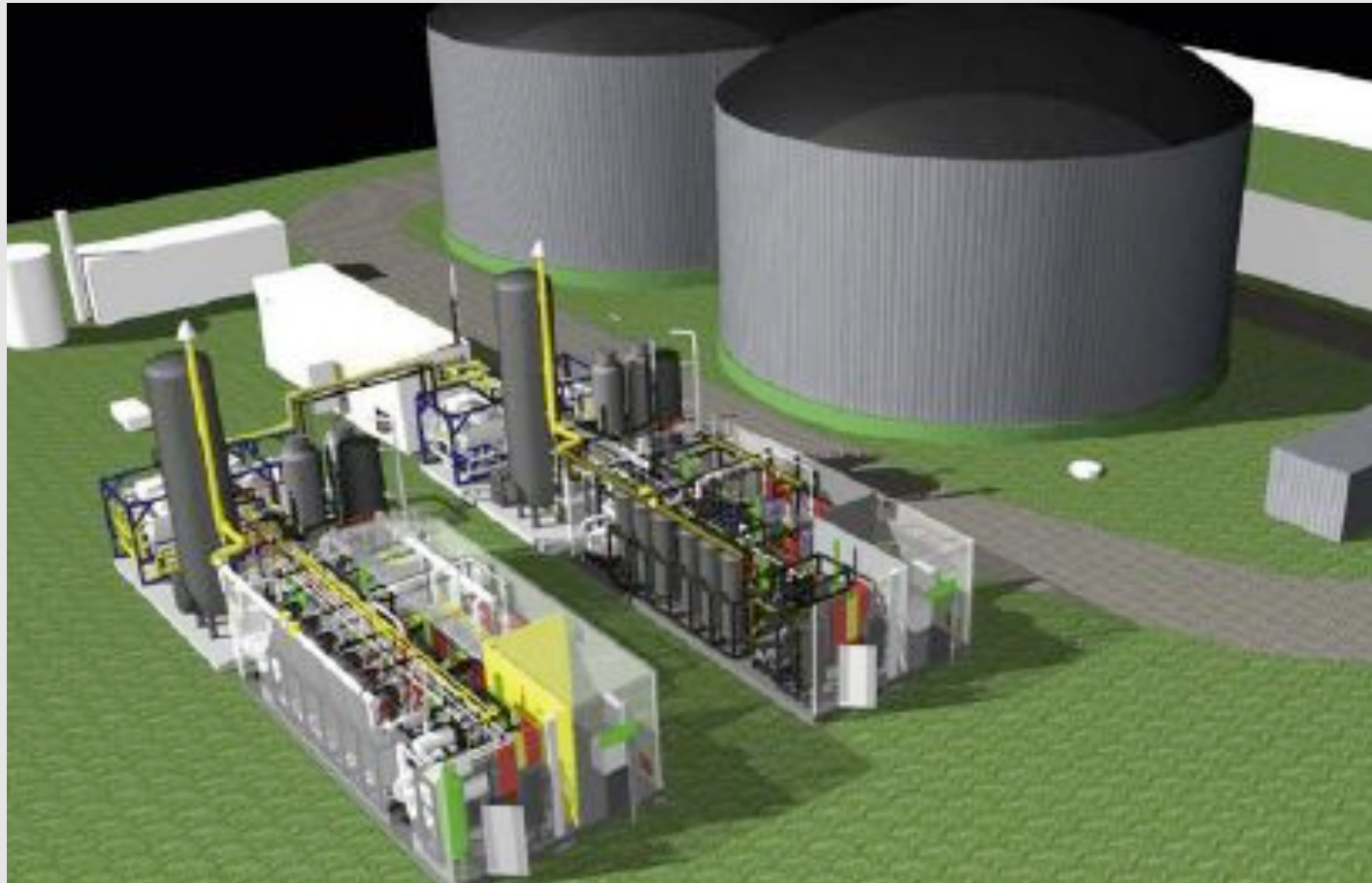

[CarboTech, 2008]

Dipl.-Ing. Michael Beil, Dipl.-Ing. Uwe Hoffstede, ISET, Division Bio-energy Systems Technology
“European Biomethane Fuel Conference”, Göteborg/Sweden, 2009-09-09

Water scrubber

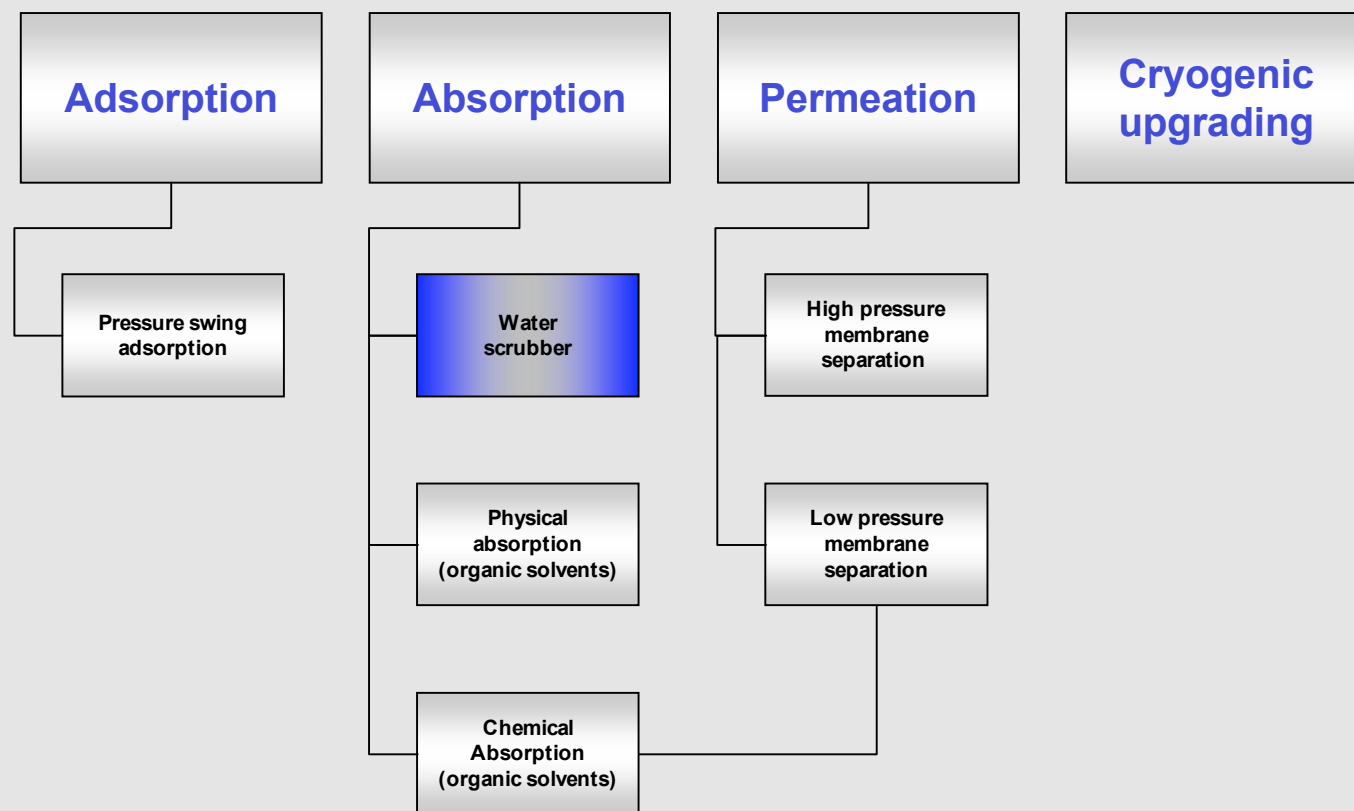

[ISET, 2008]

Water Scrubber (with regeneration)

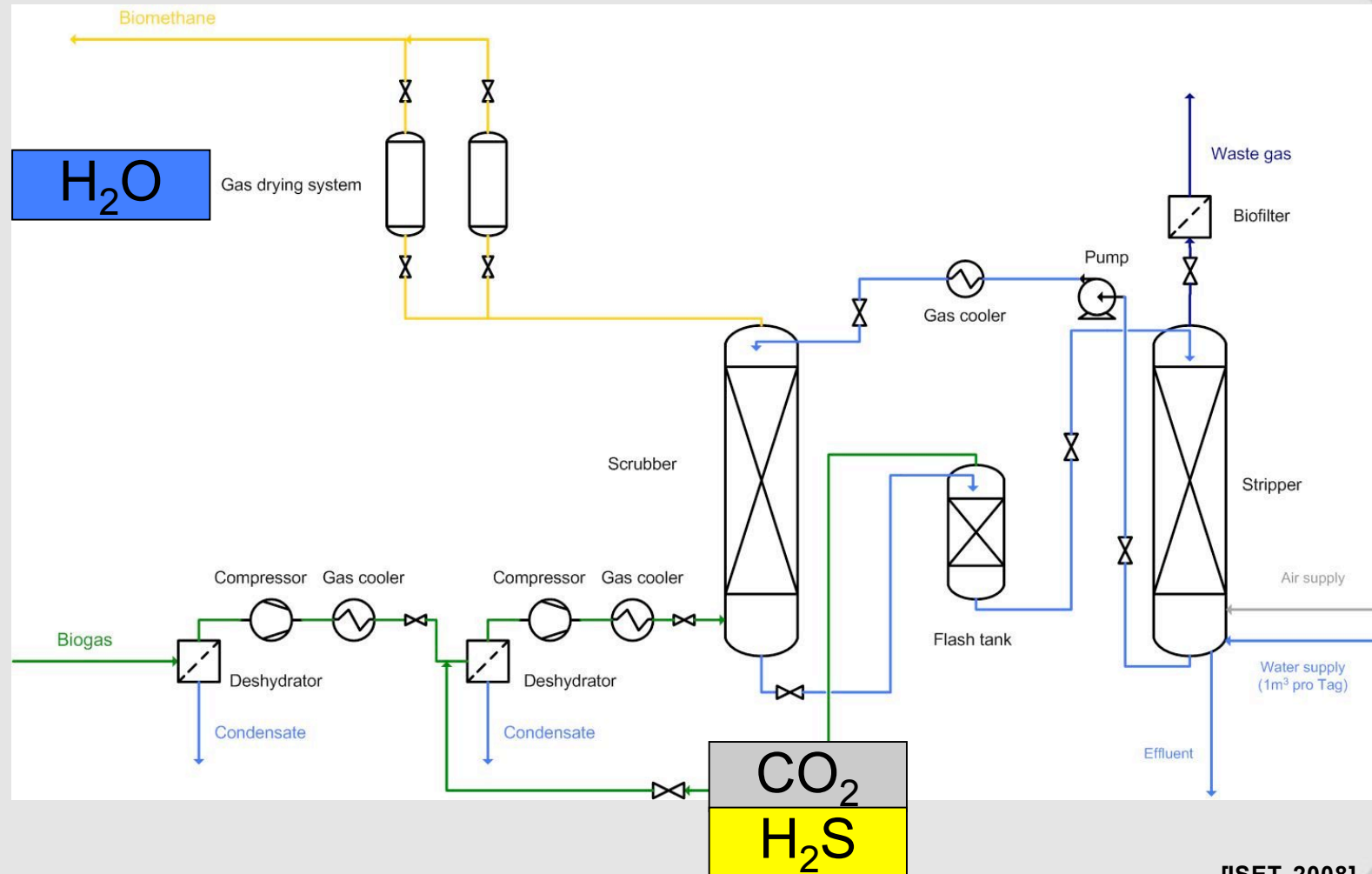

[ISET, 2008]

Water Scrubber (with regeneration)



[ISET, 2008]



[Göteborg Energi, 2008]

Dipl.-Ing. Michael Beil, Dipl.-Ing. Uwe Hoffstede, ISET, Division Bio-energy Systems Technology
“European Biomethane Fuel Conference”, Göteborg/Sweden, 2009-09-09

Physical Absorption/Scrubber (using organic solvents)

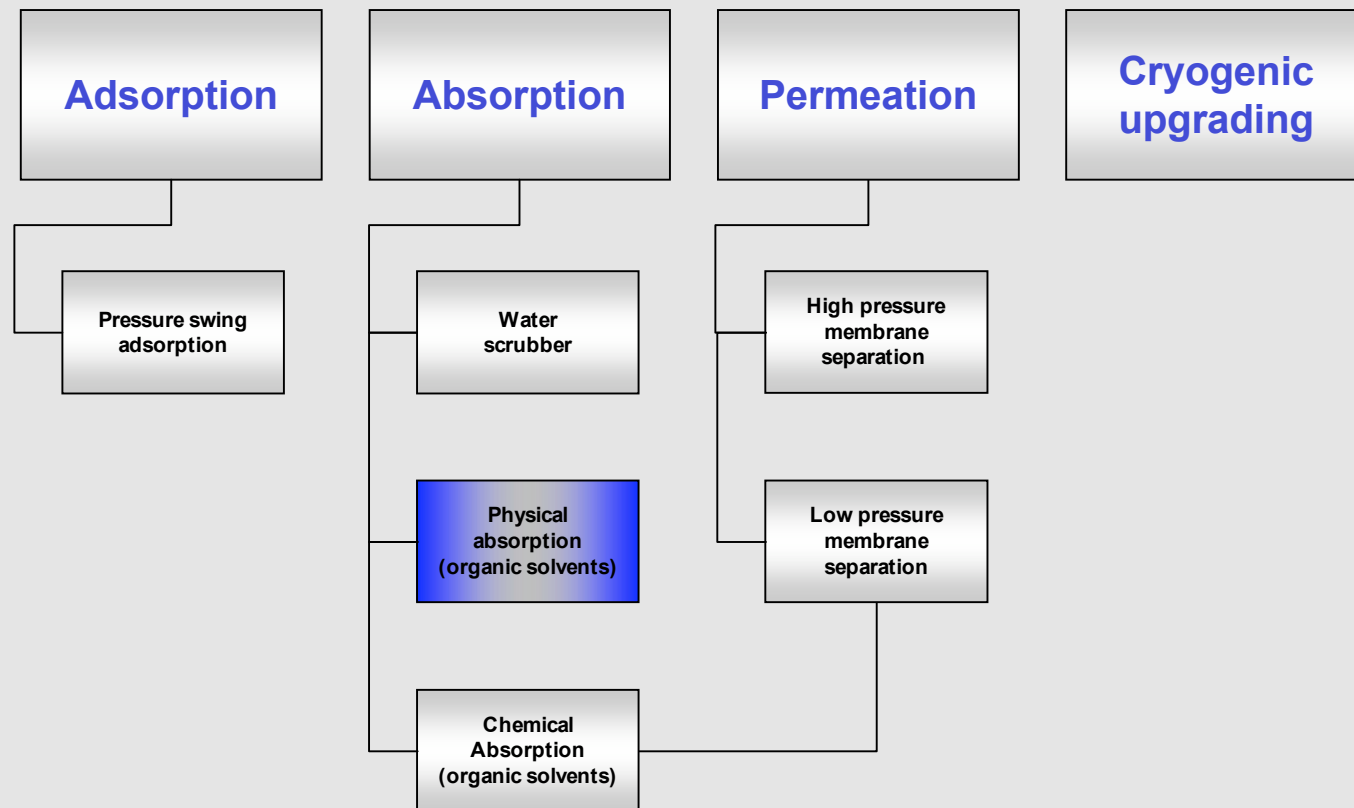

[ISET, 2008]

Physical Absorption/Scrubber (using organic solvents)

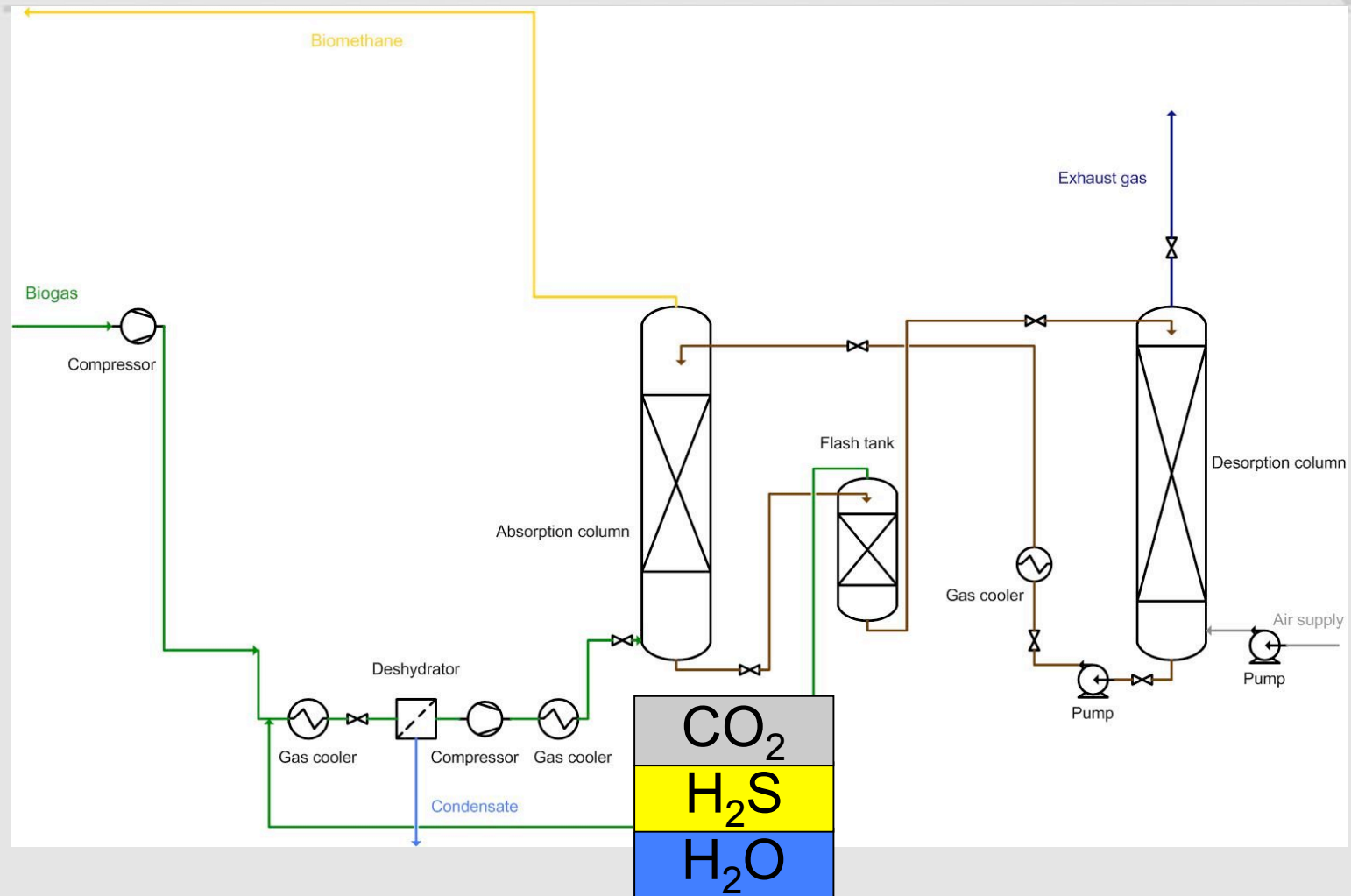

[ISET, 2008]

Chemical Absorption/Scrubber (using organic solvents)

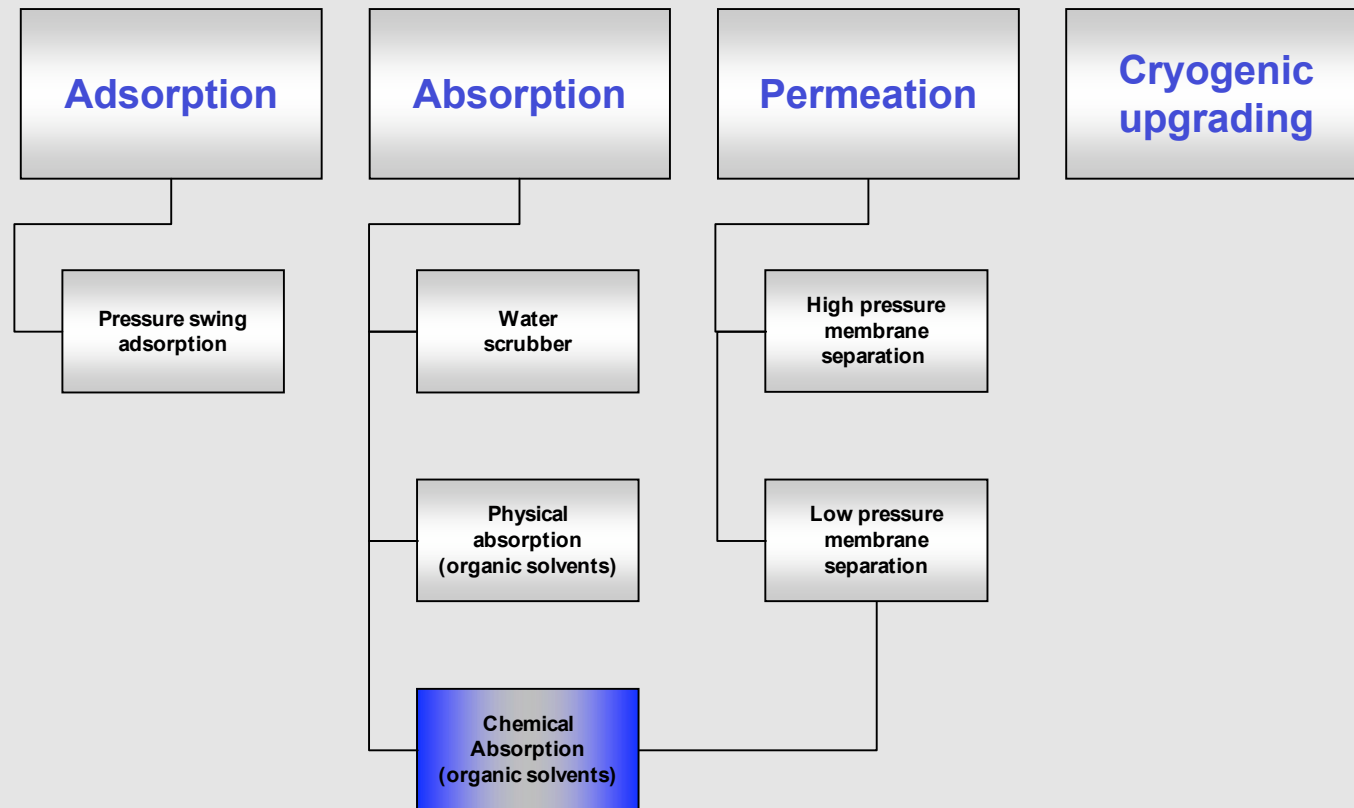

[ISET, 2008]

Chemical Absorption/Scrubber (using organic solvents)

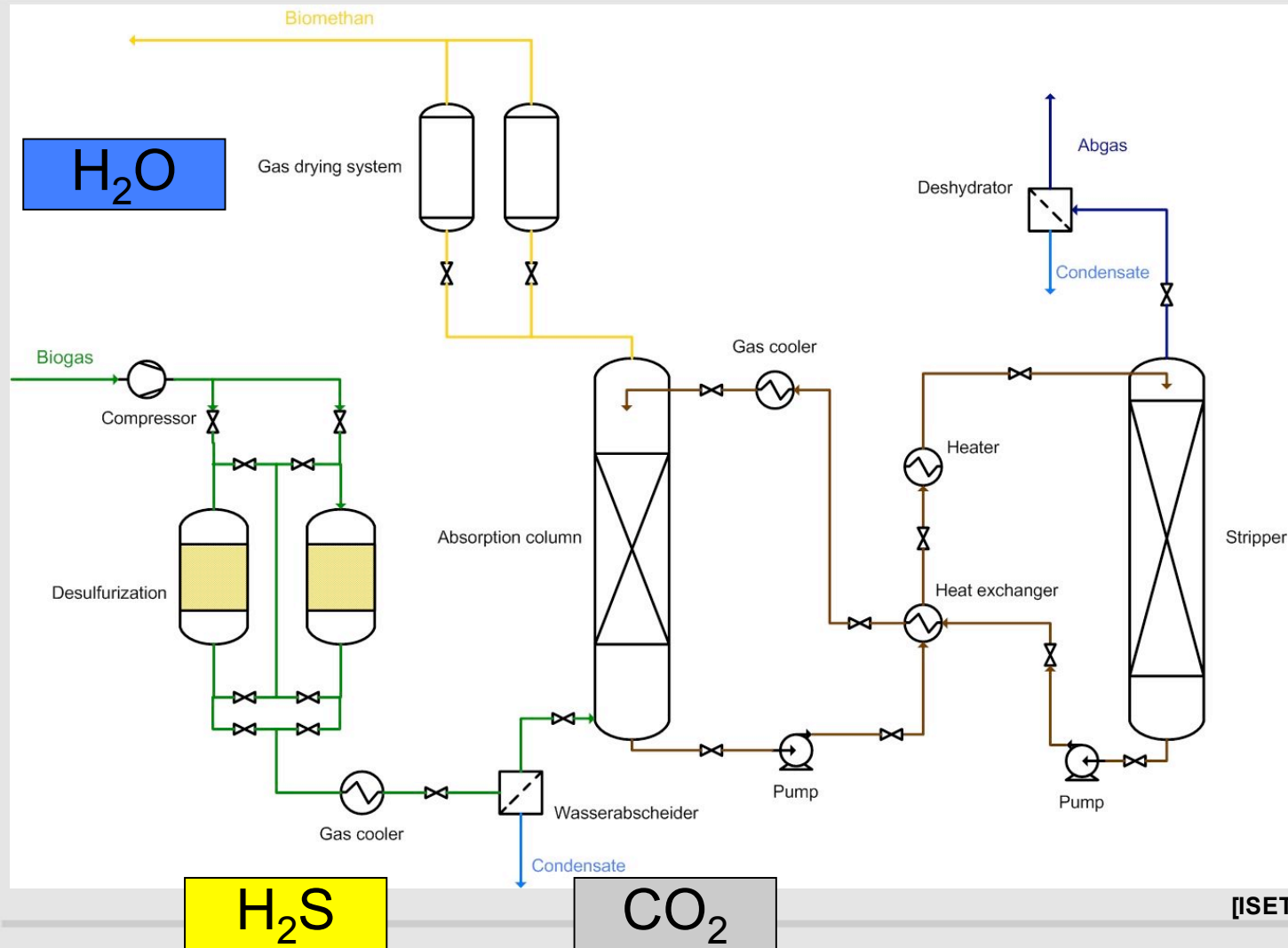

[ISET, 2008]

„Amine-scrubber“ in Gothenburg/Sweden



[Göteborg Energi, 2008]

High pressure membrane separation

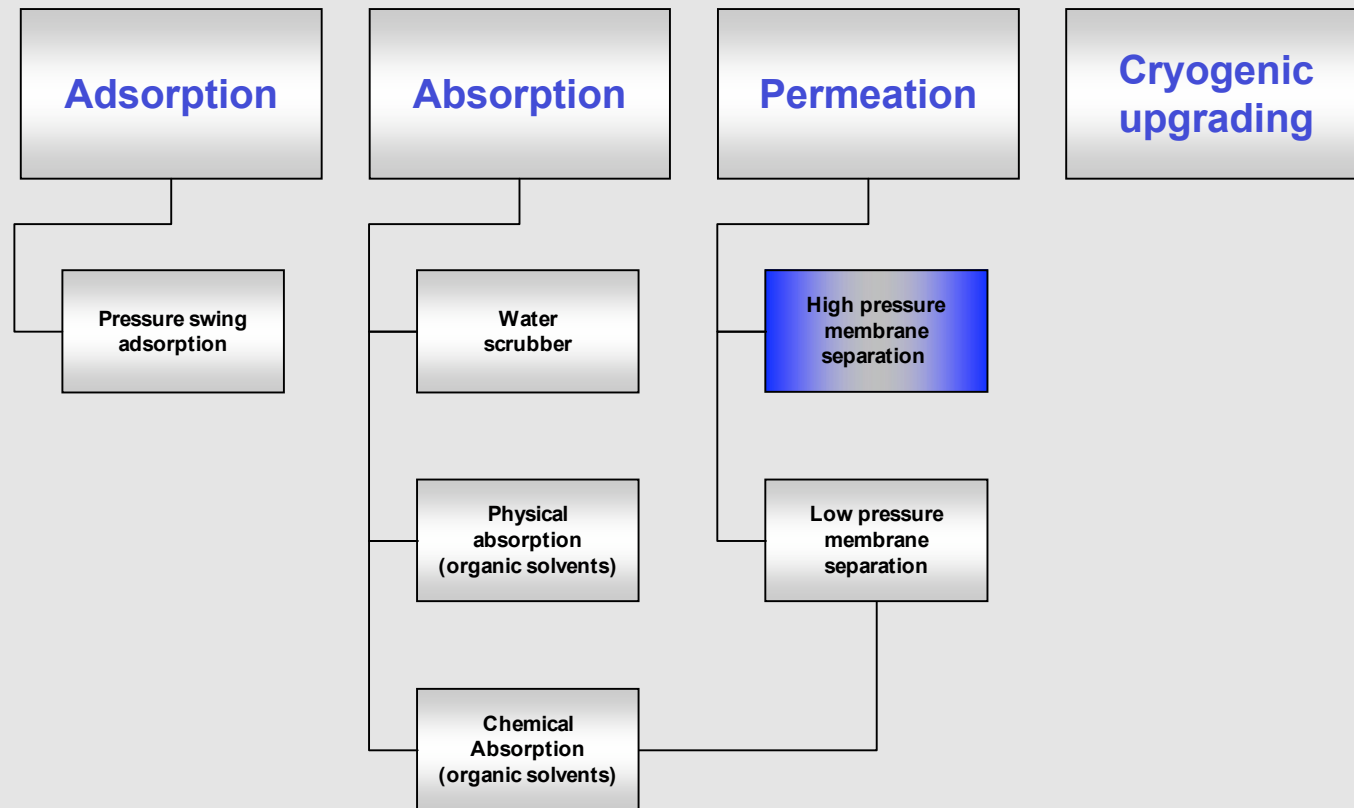

[ISET, 2008]

High pressure membrane separation

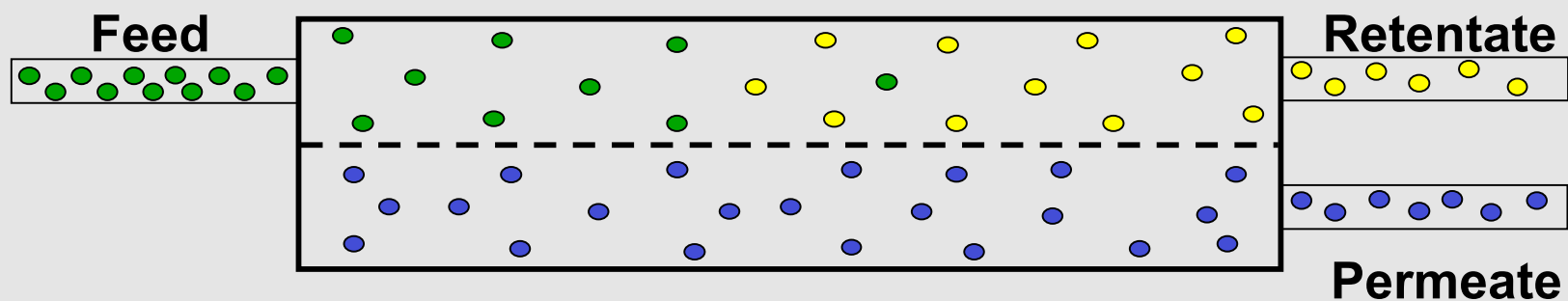
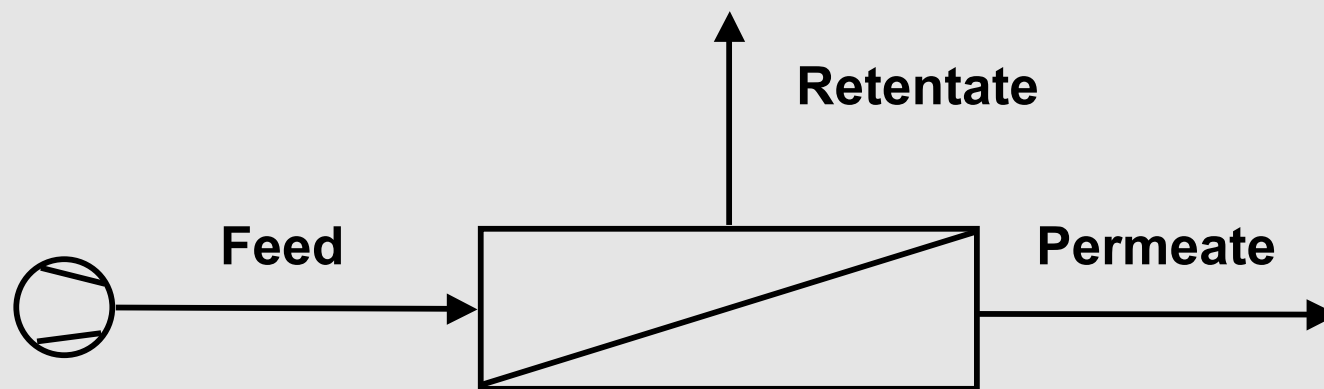

[ISET, 2008]

Energy demand biogas upgrading

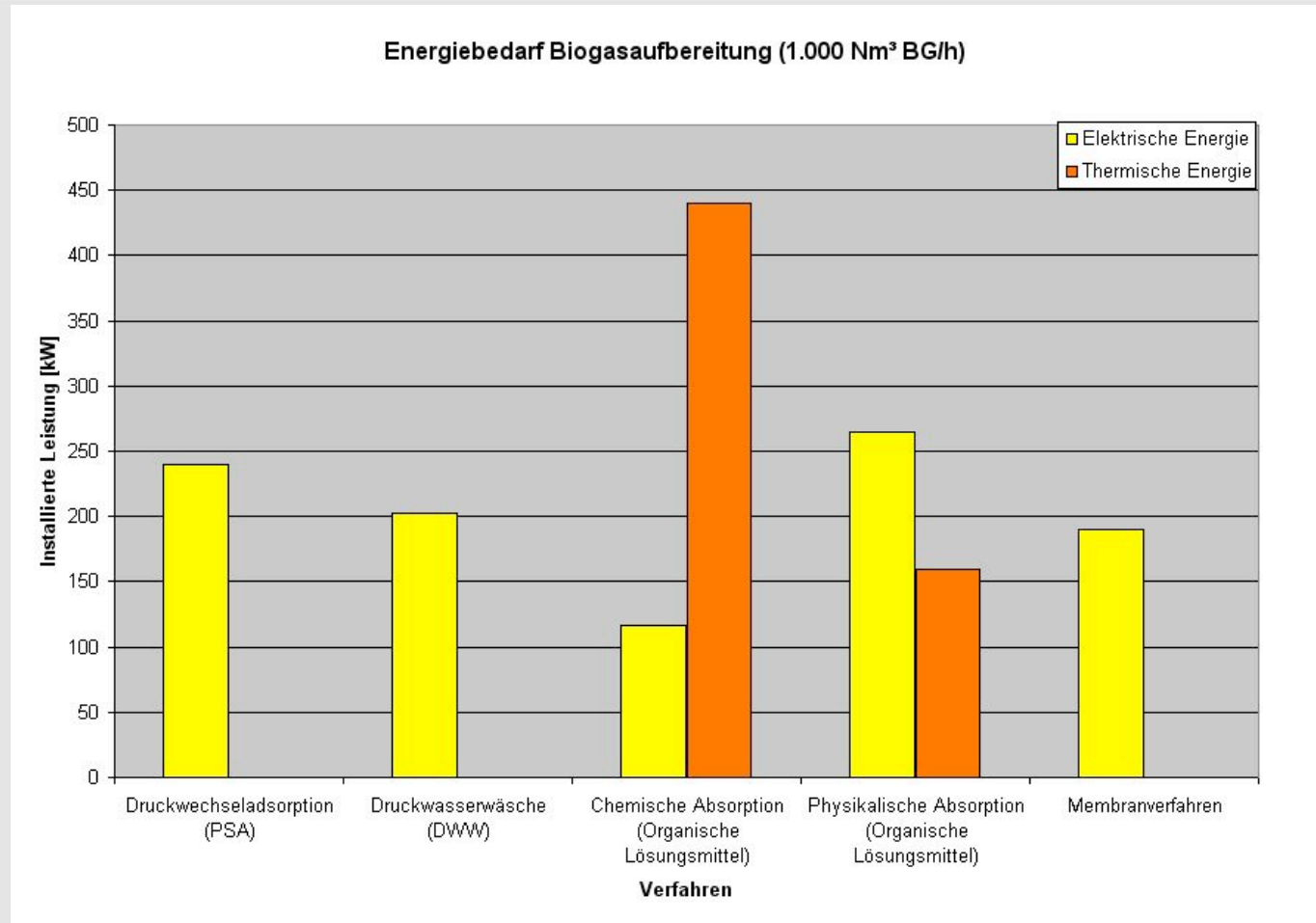

[ISET nach Schwalbenbach, Lange/Dalkia; Beil/ISET, 2008]

Costs biogas upgrading

Investment costs:

ca. 1,2 – 1,5 Mio. € (1.000 Nm³/h BG*)

ca. 0,5 – 0,8 Mio. € (250 Nm³/h BG*)

Specific operational costs:

ca. 7 – 13 €/MWh (1.000 Nm³/h BG*)

ca. 13 – 17 €/MWh (250 Nm³/h BG*)

*BG= raw BioGas

[ISET, Beil; Dalkia, Schwalbenbach/Lange, 2008]

Availability and maintenance costs biogas upgrading unit (1.000 Nm³/h raw gas)

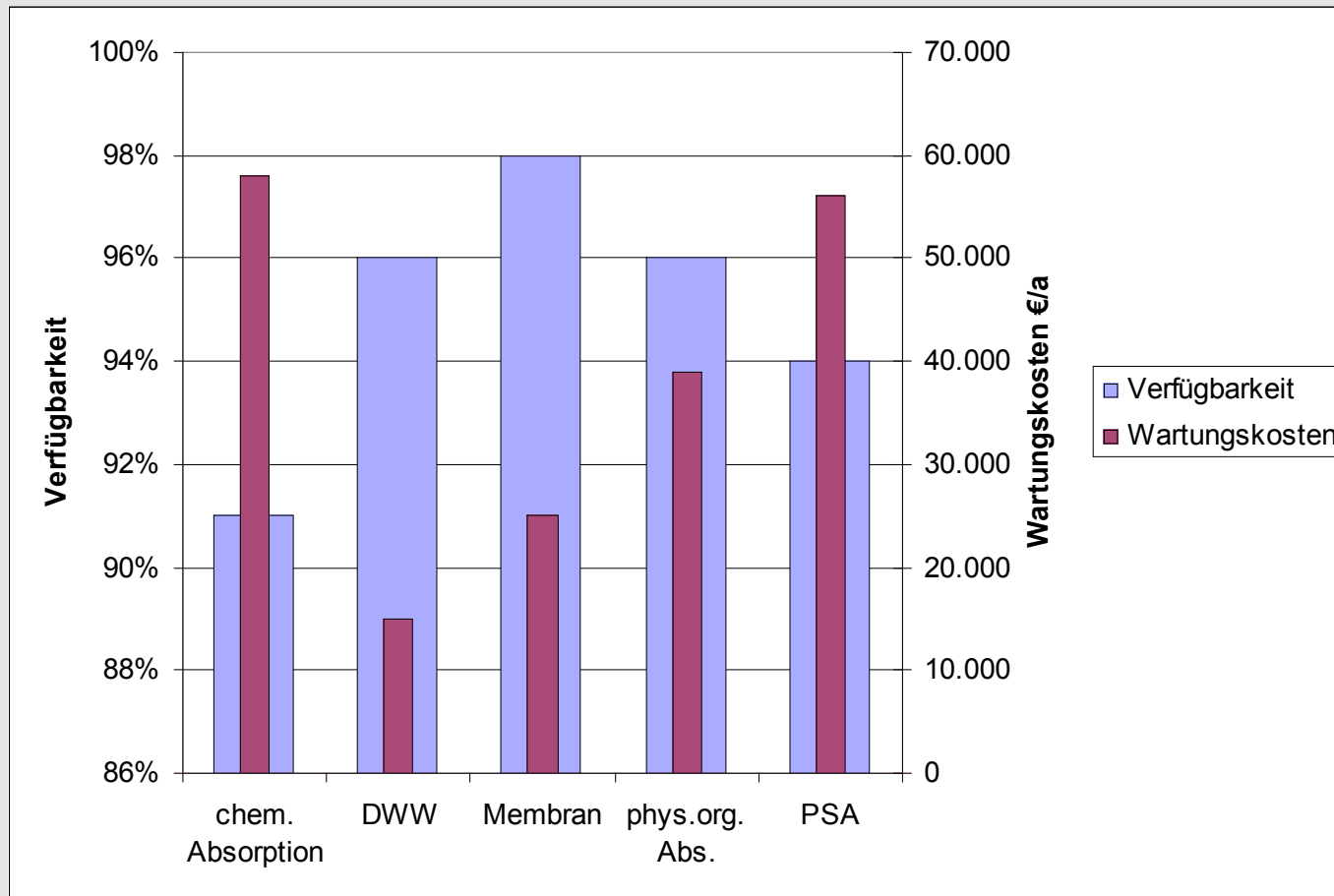

[ISET, Beil; Dalkia, Schwalbenbach/Lange, 2008]



Biogas upgrading in Europe – number of plants

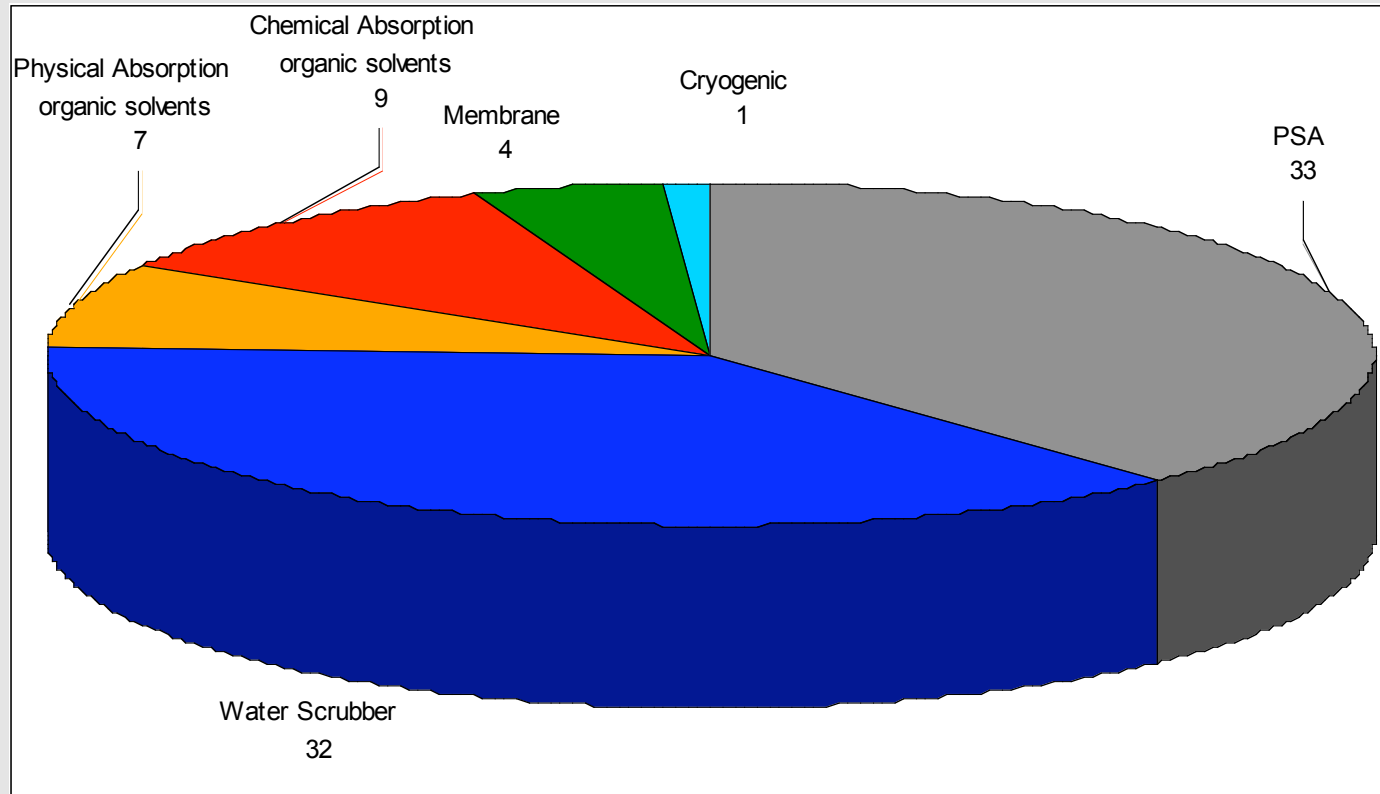

[ISET, 10/08]

Biogas upgrading in Europe – raw gas capacities in Nm³/h

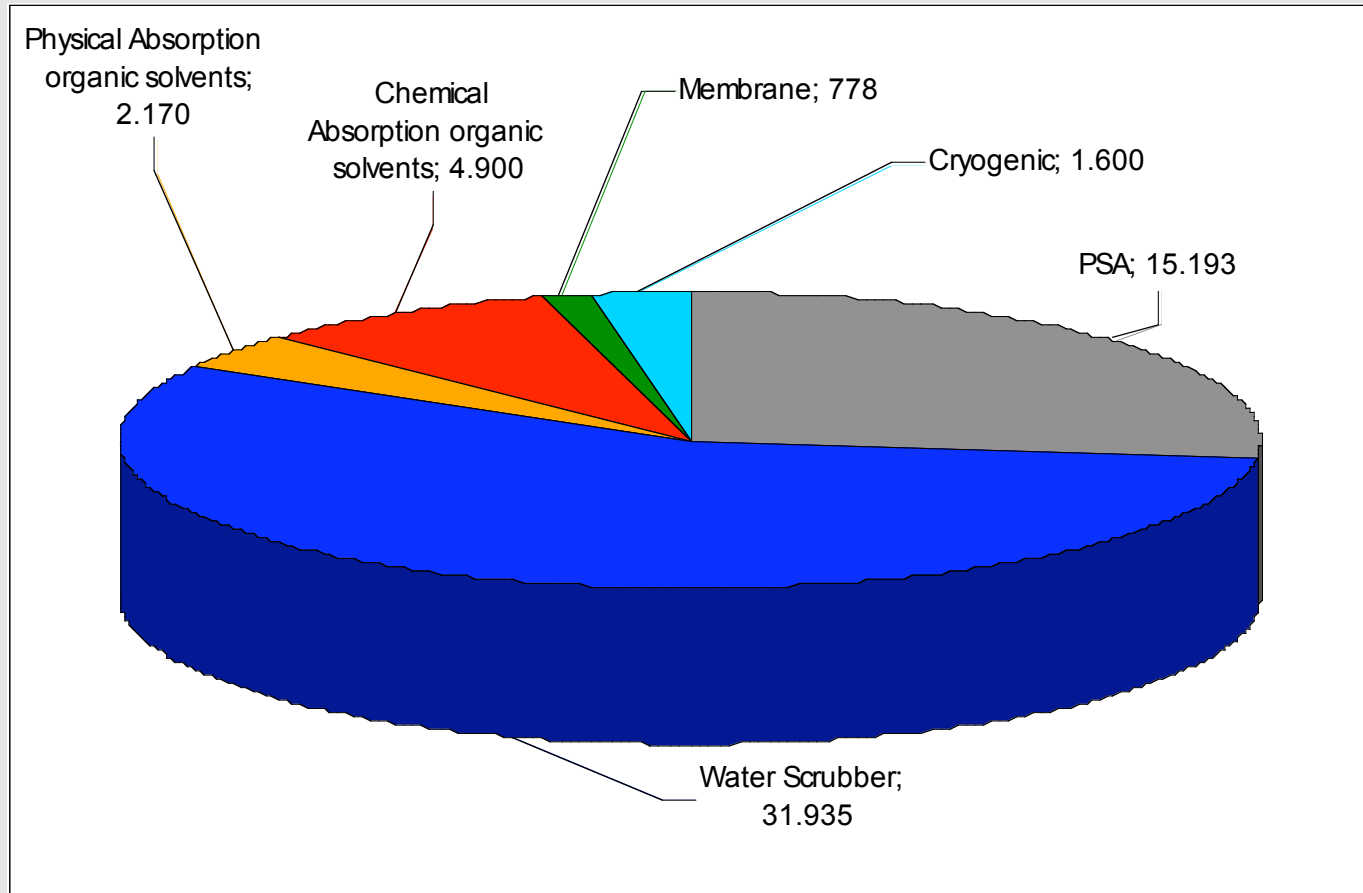

[ISET, 10/08]

Biogas upgrading in Europe

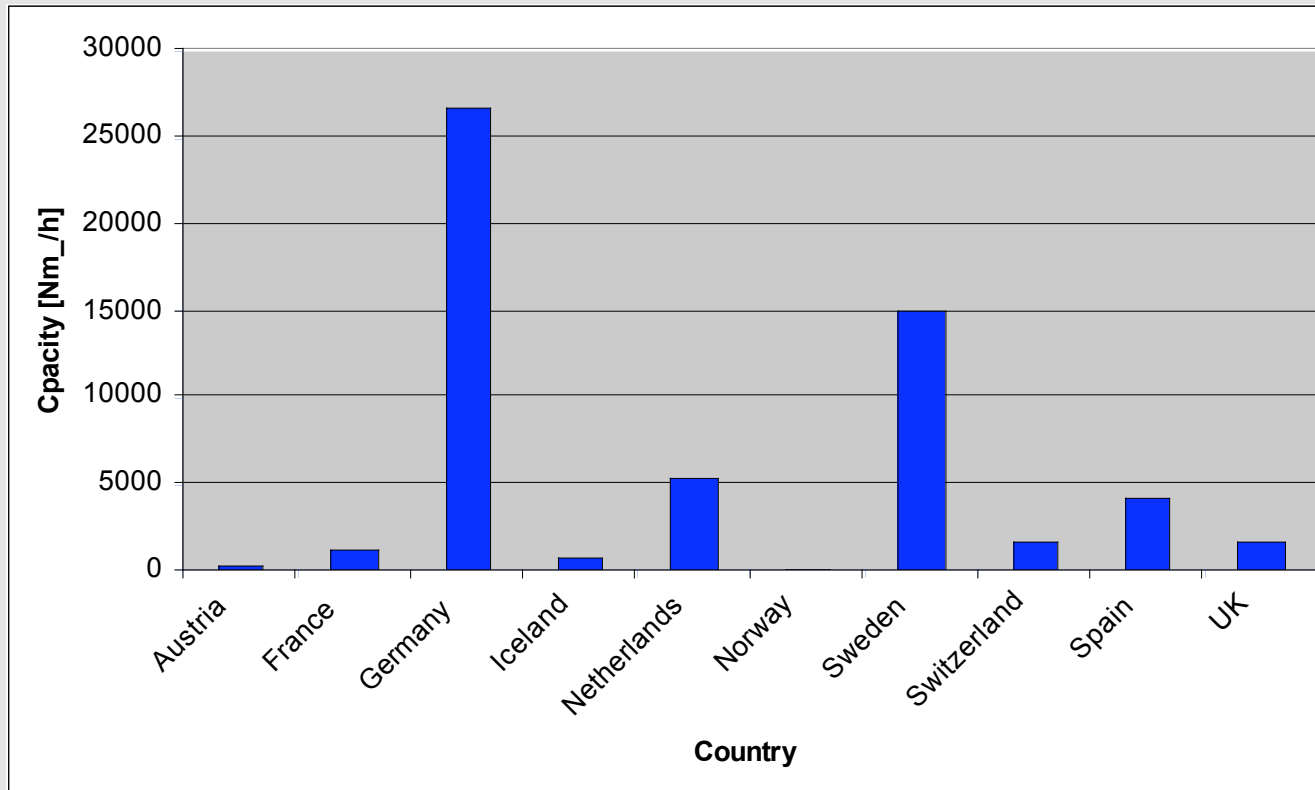

[ISET, 10/08]

Biogas upgrading to produce biomethane as vehicle fuel or grid injection



- ✎ **Upgrading technologies are available** and there is an experience of more than 20 years available.
- ✎ For the production of **vehicle fuel & grid injection** the **same upgrading technologies** can be used.
- ✓✎ Currently there is **no international standard** regarding the gas quality for grid injection and the use as vehicle fuel available (only national standards: e.g. Austria, Germany, Sweden, Switzerland)
- ✓✎ There is **no equal quality for natural gas**

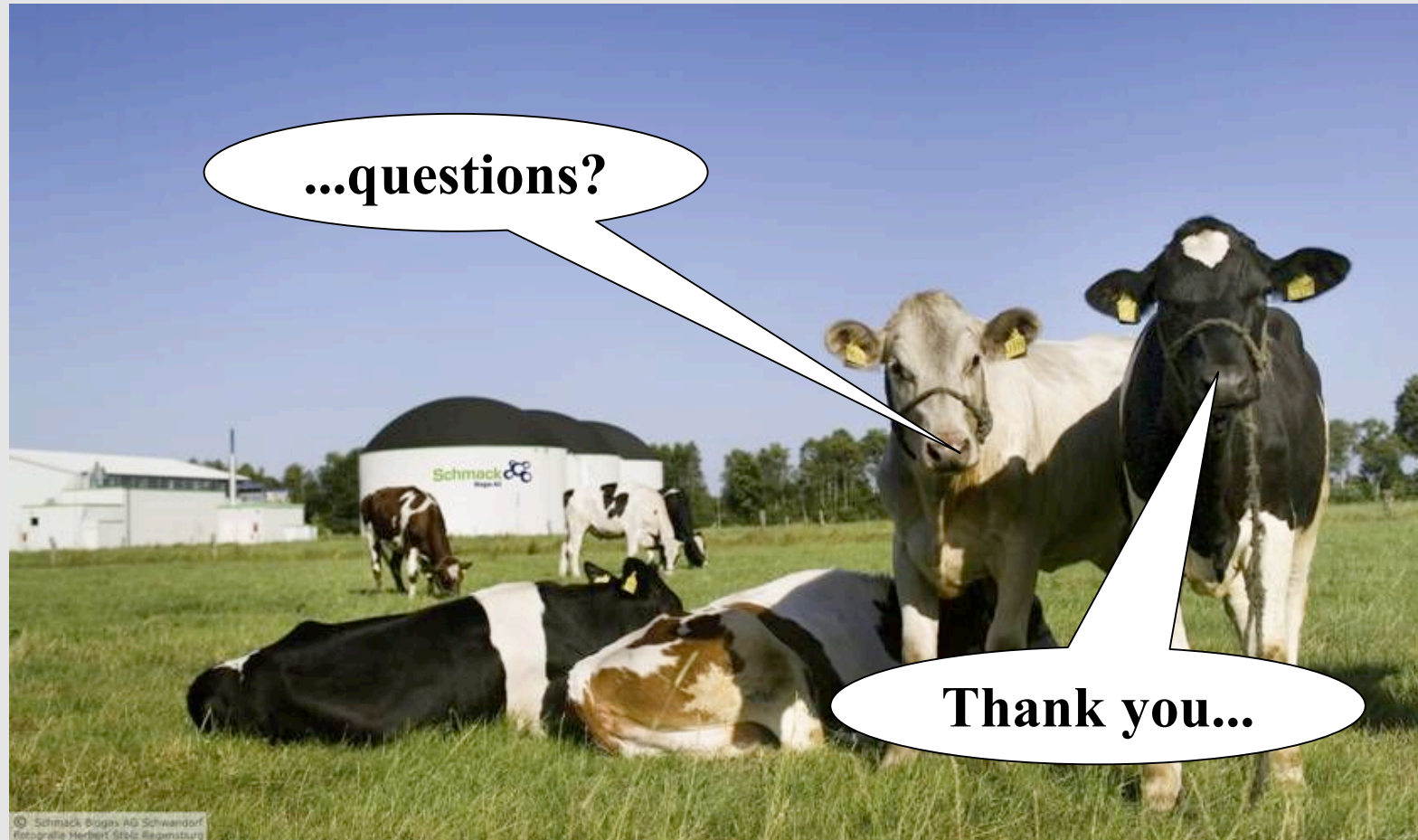

[Copyright: Schmack Biogas AG]

Further reading:



Proceedings
available at:

www.iset.de

www.fnr.de